



aerospace  
climate control  
electromechanical  
filtration  
fluid & gas handling  
hydraulics  
pneumatics  
process control  
sealing & shielding



# Stealth: The Next Generation

PS/PX/RS/RX Series Gearheads

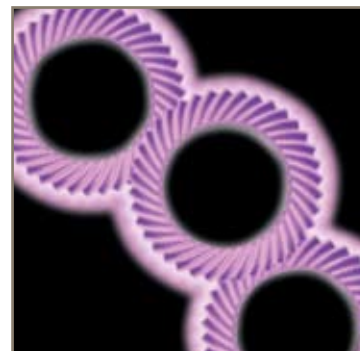

ENGINEERING YOUR SUCCESS.

# Parker Hannifin Corporation

A Fortune 300 company with annual sales exceeding \$10 billion and more than 400,000 customers in 43 countries, Parker Hannifin is the world's leading supplier of innovative motion control components and system solutions serving the industrial, mobile, and aerospace markets. We are the only manufacturer offering customers a choice of electromechanical, hydraulic, pneumatic, or computer-controlled motion systems.

## Total System Solutions

Parker's team of highly qualified application engineers, product development engineers, and system specialists can turn pneumatic, structural, and electromechanical products into an integrated system solution. Moreover, our Selectable Levels of Integration™ allows you to choose the appropriate system, subsystem, or component to meet your specific need.

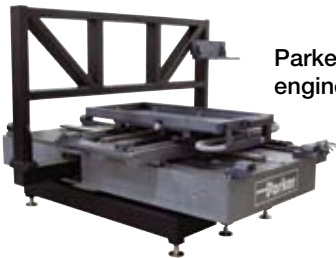

Parker offers complete engineered systems.

## First in Delivery, Distribution, and Support

In today's competitive, fast-moving economy, what good is an application that isn't ready on time? This is especially true when compressed design cycles make the quick delivery of critical components essential. With factories strategically located on five continents, Parker offers an unrivaled delivery record, getting solutions out our door and onto your floor faster than ever.

Parker also has the industry's largest global distribution network, with more than 8,600 distributors worldwide. Each of these locations maintains ample product inventory to keep your downtime to a minimum. And many distributors have in-house design capabilities to support your system and subsystem requirements.

Throughout the design process, Parker's factory-trained electromechanical engineers work hand in hand with you and day or night at 1-800-C-Parker. Our operators will connect you with a live, on-call representative who will identify replacement parts or services for all motion technologies.



© Copyright 2008, Parker Hannifin Corporation. All rights reserved.



Parker world headquarters in Cleveland



## Training

Parker's best-in-class technology training includes hands-on classes, Web-based instruction, and comprehensive texts for employees, distributors, and customers. Parker

also provides computer-based training, PowerPoint presentations, exams, drafting and simulation software, and trainer stands.

## parkermotion.com

Our award-winning Web site is your single source for

- Product information
- Downloadable catalogs
- Motion-sizing software
- 3D design files
- Training materials
- Product-configuration software
- RFQ capabilities
- Videos and application stories



## 24/7 Emergency Breakdown Support

The Parker product information center is available any time of the day or night at 1-800-C-Parker. Our operators will connect you with a live, on-call representative who will identify replacement parts or services for all motion technologies.

# PS/PX/RS/RX Series Stealth Generation II Precision Planetary Gearheads



Gen II Gearheads Provide Higher Radial Load, Increased Service Life and Ease of Mounting

## Features & Benefits

- **Higher radial load capacity:**  
Widely spaced angular contact output bearings
- **Increased service life:**  
Full complement needle planet bearings
- **Universal mounting kits:**  
Quicker deliveries and easier mounting
- **High torque and low backlash:**  
Helical planetary gearing
- **High stiffness:**  
Integral ring gear and rigid sun gear
- **Higher gear wear resistance:**  
Plasma Nitriding heat treating

The Stealth Gen II Helical Planetary Gearheads incorporate design enhancements to provide superior performance for the most demanding high performance applications.

Stealth Gen II incorporates dual angular contact bearings providing higher radial load capacities while maintaining high input speeds. Design enhancements also include full complement needle bearings allowing for increased service life and extended warranties. Internal design changes and optimized gearing geometries allow for one fill level for any orientation, resulting in shortened part number designation and simplified order placement.

Universal mounting kits provide common mounting kits across multiple product lines to promote quicker deliveries and ease of mounting to any servo motor.

Applications that require either high precision (PS/RS Series Gearheads), mid-range precision (PX/RX Series Gearheads) or lower precision (PV Series Gearheads) utilize the same mounting kit part numbers within the same frame size.

Mounting to any servo motor is as easy as A-B-C (adapter, bushing, collet).

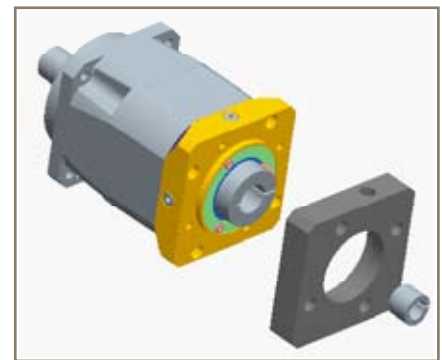

Product Series	Page	Gear Geometry	Configuration	Frame Sizes* (mm)	Continuous Torque (Nm)	Radial Load (N)	Service Life (hrs)	Backlash
PS	2	Helical Planetary	In-Line	60 to 115	40 to 190	>7500	20,000	<3
PX	6	Helical Planetary	In-Line	60 to 115 (NEMA 23 to 42)	30 to 150	>5500	20,000	<6
RS	10	Helical Planetary/ Spiral Bevel	Right Angle	60 to 115	35 to 190	>7500	20,000	<4
RX	14	Helical Planetary/ Spiral Bevel	Right Angle	60 to 115 (NEMA 23 to 42)	25 to 150	>5500	20,000	<12

\* Gen II initial release covers three frame sizes. Larger frame sizes to be released at a later date.

PS Gen II Performance Specifications

Parameter	Units	Ratio	PS60 Gen II	PS90 Gen II	PS115 Gen II
Nominal Output Torque <sup>1)</sup> $T_{nom r}$	Nm (inlbs)	3,15,30	27 (239)	76 (673)	172 (1,522)
		4,5,7,20,25,40,50,70	37 (327)	110 (974)	230 (2,036)
		10,100	32 (283)	93 (823)	205 (1,814)
Maximum Acceleration Output Torque <sup>2)</sup> $T_{acc r}$	Nm (inlbs)	3,15,30	34 (300)	105 (930)	225 (1,990)
		4,5,7,20,25,40,50,70	48 (425)	123 (1,090)	285 (2,525)
		10,100	37 (325)	112 (990)	240 (2,125)
Emergency Stop Output Torque <sup>3)</sup> $T_{em r}$	Nm (inlbs)	3,15,30	80 (710)	260 (2,300)	600 (5,310)
		4,5,7,20,25,40,50,70	70 (620)	230 (2,035)	500 (4,425)
		10,100	60 (530)	200 (1,770)	430 (3,805)
Nominal Input Speed $N_{nom r}$	RPM	3	3000	2500	2000
		4,5	3500	3000	2500
		7,10,15	4000	3500	3000
		20,25,30	4500	4000	3500
		40,50	4800	4400	3800
		70,100	5200	4800	4200
Maximum Input Speed $N_{max r}$ <sup>4)</sup>	RPM	3-100	6000	5500	4500
Maximum Radial Load $P_{r,max}$ <sup>5,7)</sup>	N (lbs)		1650 (370)	4800 (1,080)	7500 (1,685)
Maximum Axial Load $P_{a,max}$ <sup>6)</sup>	N (lbs)		2100 (475)	3600 (810)	6800 (1,530)
Service Life	h		20,000		
Standard Backlash <sup>8)</sup>	arc min	3 to 10	<6	<6	<4
		15 to 100	<8	<8	<6
Low Backlash <sup>8)</sup>	arc min	3 to 10	<4	<4	<3
		15 to 100	<6	<6	<5
Efficiency at Nominal Torque	%	3 to 10	97	97	97
		15 to 100	94	94	94
Noise Level at 3000 RPM <sup>9)</sup>	db	3-100	<62	<62	<65
Torsional Stiffness	Nm/arcmin (inlb/arcmin)	3-100	3 (27)	12 (105)	27 (240)
Maximum Allowable Case Temperature	° C	3-100	-20 to 90		
Lubrication		3-100	Per Maintenance Schedule		
Mounting Position		3-100	Any		
Direction of Rotation		3-100	Same as Input		
Degree of Protection			IP65		
Maximum Weight	kg (lbs)	3 to 10	1.3 (2.9)	3.0 (6.6)	7.0 (15.4)
		15 to 100	1.7 (3.7)	5.0 (11.0)	10.0 (22.0)

1) At nominal speed  $N_{nom r}$ .

2) See gearhead selection program.

3) Maximum of 1000 stops.

4) For intermittent operation.

5) Max Radial Load applied to the center of the shaft at 100 rpm.

6) Max Axial Load at 100 rpm.

7) For combine Radial and Axial load consult Factory or use our software on the company website.

8) Measured at 2% of rated torque.

9) Measure at 1m.



## PS Gen II Output Shaft Load Rating

### PS60

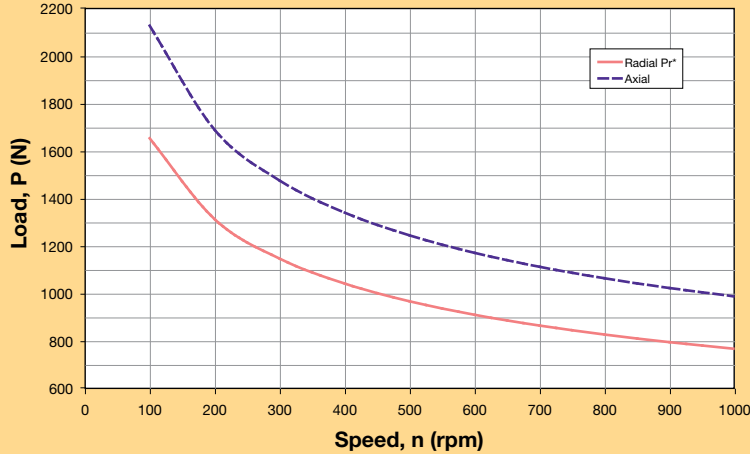

Formulas to calculate radial load (Prx) at any distance "X" from the gearhead mounting surface:

$$Pr_x = Pr * 75 \text{ mm} / (49 + X)$$

$$Pr_x = Pr * 2.95 \text{ in} / (1.93 \text{ in} + X)$$

### PS90

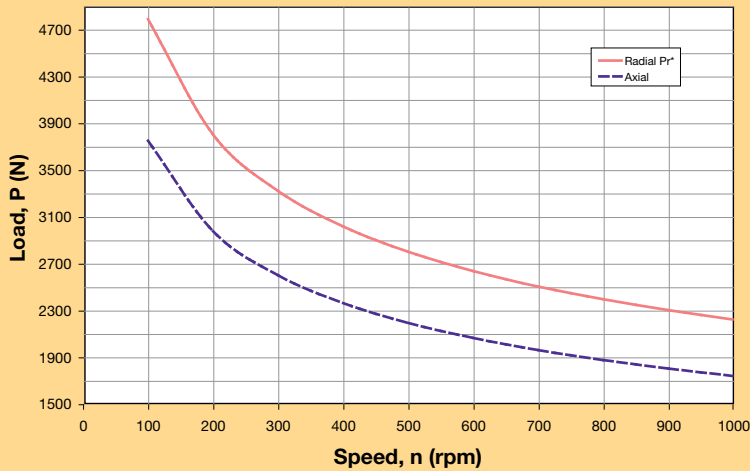

$$Pr_x = Pr * 96 \text{ mm} / (62 + X)$$

$$Pr_x = Pr * 3.78 \text{ in} / (2.44 \text{ in} + X)$$

### PS115

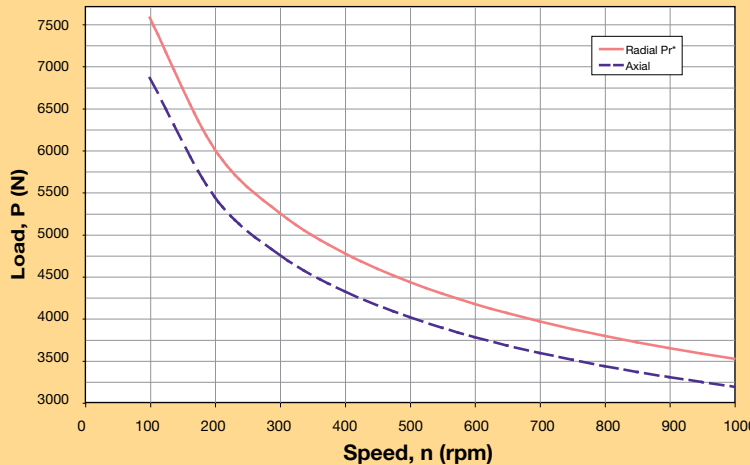

$$Pr_x = Pr * 124 \text{ mm} / (81 + X)$$

$$Pr_x = Pr * 4.88 \text{ in} / (3.19 \text{ in} + X)$$

\* Radial load applied to center of the shaft.

PS Series Gen II Dimensions

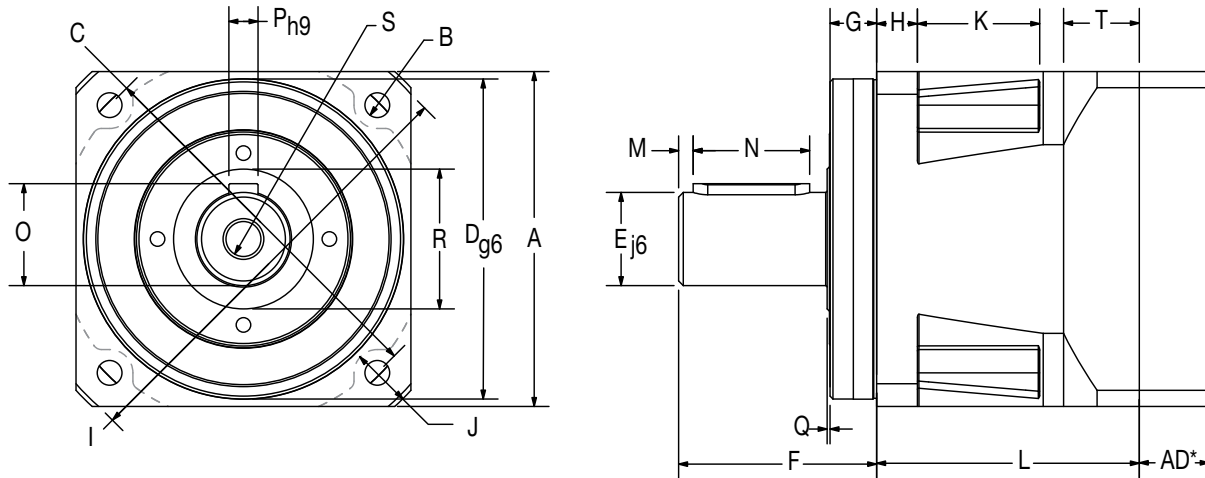

Metric Frame Sizes

Frame Size	A		B		C		D		E		F		G		H		I		J		K	
	Square Flange	Bolt Hole	Bolt Circle	Pilot Diameter	Output Shaft Diameter	Output Shaft Length	Pilot Thickness	Flange Thickness	Housing Diameter	Housing Recess	Recess Length											
	(mm) (in)	(mm) (in)	(mm) (in)	(mm) (in)	(mm) (in)	(mm) (in)	(mm) (in)	(mm) (in)	(mm) (in)	(mm) (in)	(mm) (in)	(mm) (in)	(mm) (in)	(mm) (in)	(mm) (in)	(mm) (in)	(mm) (in)	(mm) (in)	(mm) (in)	(mm) (in)	(mm) (in)	
<b>PS60</b>	62 2.441	5.5 0.217	70 2.756	50 1.969	16 0.630	40 1.575	11 0.433	8 0.315	80 3.150	5 0.197	24 0.945											
<b>PS90</b>	90 3.543	6.5 0.256	100 3.937	80 3.150	22 0.866	52 2.047	15 0.591	10 0.394	116 4.567	6.5 0.256	33 1.299											
<b>PS115</b>	115 4.528	8.5 0.335	130 5.118	110 4.331	32 1.260	68 2.677	16 0.630	14 0.551	152 5.984	7.5 0.295	42 1.654											

Frame Size	L1		L2		M		N		O		P		Q		R		S		T	
	Length Single Stage	Length Double Stage	Distance from Shaft End	Keyway Length	Key Height	Keyway Width	Shoulder Height	Shoulder Diameter	Tap & Depth (end of shaft)	Rear Housing Thickness										
	(mm) (in)	(mm) (in)	(mm) (in)	(mm) (in)	(mm) (in)	(mm) (in)	(mm) (in)	(mm) (in)	(mm) (in)	(mm) (in)	(mm) (in)	(mm) (in)	(mm) (in)	(mm) (in)	(mm) (in)	(mm) (in)	(mm) (in)	(mm) (in)	(mm) (in)	
<b>PS60</b>	59.8 2.354	94.8 3.732	2 0.079	25 0.984	18 0.709	5 0.197	1 0.039	22 0.866	M5x8	20.3 0.799										
<b>PS90</b>	69.5 2.736	113 4.449	3 0.118	32 1.260	24.5 0.965	6 0.236	1 0.039	35 1.378	M8x16	20 0.787										
<b>PS115</b>	90.2 3.551	143.4 5.646	5 0.197	40 1.575	35 1.378	10 0.394	1.5 0.059	50 1.969	M12x25	26 1.024										



## Universal Mounting Kits

Adapter Length "AD" Dimension

Frame Size	Motor Shaft Length		Gearhead Adapter Length	
	mm	(in)	mm	(in)
60	16 thru 35	(0.630 thru 1.378)	16.5	(0.65)
	35.1 thru 41	(1.382 thru 1.614)	22.5	(0.886)
90	20 thru 40	(0.787 thru 1.575)	20	(0.787)
	40.1 thru 48	(1.579 thru 1.890)	28.5	(1.122)
115	22 thru 50	(0.866 thru 1.969)	24	(0.945)
	50.1 thru 61	(1.972 thru 2.402)	35	(1.378)

## PS Series Gen II Inertia

All moment of inertia values are as reflected at the input of the gearhead

Ratio	Units*	PS60	PS90	PS115
3	kg cm <sup>2</sup>	0.2500	0.9700	3.4000
	in lb sec <sup>2</sup>	0.000221	0.000858	0.003009
4	kg cm <sup>2</sup>	0.1700	0.6700	2.2000
	in lb sec <sup>2</sup>	0.000150	0.000593	0.001947
5	kg cm <sup>2</sup>	0.1500	0.5100	1.7000
	in lb sec <sup>2</sup>	0.000133	0.000451	0.001505
7	kg cm <sup>2</sup>	0.1400	0.4100	1.3000
	in lb sec <sup>2</sup>	0.000124	0.000363	0.001151
10	kg cm <sup>2</sup>	0.1400	0.3700	1.1000
	in lb sec <sup>2</sup>	0.000124	0.000327	0.000974
15	kg cm <sup>2</sup>	0.1500	0.5200	0.1700
	in lb sec <sup>2</sup>	0.150000	0.000460	0.000150
20	kg cm <sup>2</sup>	0.1500	0.5100	1.7000
	in lb sec <sup>2</sup>	0.000133	0.000451	0.001505
25	kg cm <sup>2</sup>	0.1500	0.5100	1.7000
	in lb sec <sup>2</sup>	0.000133	0.000451	0.001505
30, 40, 50, 70, 100	kg cm <sup>2</sup>	0.1300	0.3700	1.1000
	in lb sec <sup>2</sup>	0.000115	0.000327	0.000974

\* Note: 1 kg cm<sup>2</sup> = 0.000885 in lb sec<sup>2</sup>

## PX Gen II Performance Specifications

Parameter	Units	Ratio	PX60 Gen II	PX90 Gen II	PX115 Gen II
<b>Nominal Output Torque</b> <sup>1)</sup> $T_{nom r}$	Nm (inlbs)	3,15,30	20 (177)	56 (496)	120 (1,062)
		4,5,7,20,25,40,50,70	32 (283)	66 (584)	152 (1,345)
		10,100	25 (221)	60 (531)	160 (1,416)
<b>Maximum Acceleration Output Torque</b> <sup>2)</sup> $T_{acc r}$	Nm (inlbs)	3,15,30	27 (240)	84 (743)	180 (1,593)
		4,5,7,20,25,40,50,70	39 (345)	98 (867)	228 (2,018)
		10,100	30 (265)	90 (797)	192 (1,700)
<b>Emergency Stop Output Torque</b> <sup>3)</sup> $T_{em r}$	Nm (inlbs)	3,15,30	64 (565)	208 (1,840)	480 (4,248)
		4,5,7,20,25,40,50,70	56 (495)	184 (1,628)	400 (3,540)
		10,100	48 (425)	160 (1,416)	344 (3,044)
<b>Nominal Input Speed</b> $N_{nom r}$	RPM	3	3000	2500	2000
		4,5	3500	3000	2500
		7,10,15	4000	3500	3000
		20,25,30	4500	4000	3500
		40,50	4800	4400	3800
		70,100	5200	4800	4200
<b>Maximum Input Speed</b> $N_{max r}$ <sup>4)</sup>	RPM	3-100	6000	5500	4500
<b>Maximum Radial Load</b> $P_{r,max}$ <sup>5,7)</sup>	N (lbs)		1550 (348)	2800 (630)	5500 (1,235)
<b>Maximum Axial Load</b> $P_{a,max}$ <sup>6)</sup>	N (lbs)		2100 (475)	3600 (810)	6800 (1,530)
<b>Service Life</b>	h		20,000		
<b>Standard Backlash</b> <sup>8)</sup>	arc min	3 to 10	<10	<9	<8
		15 to 100	<12	<11	<10
<b>Low Backlash</b> <sup>8)</sup>	arc min	3 to 10	<8	<7	<6
		15 to 100	<10	<9	<8
<b>Efficiency at Nominal Torque</b>	%	3 to 10	97	97	97
		15 to 100	94	94	94
<b>Noise Level at 3000 RPM</b> <sup>9)</sup>	db	3-100	<62	<62	<65
<b>Torsional Stiffness</b>	Nm/arcmin (inlb/arcmin)	3-100	2.5 (22)	10 (90)	22 (195)
<b>Maximum Allowable Case Temperature</b>	° C	3-100	-20 to 90		
<b>Lubrication</b>		3-100	Per Maintenance Schedule		
<b>Mounting Position</b>		3-100	Any		
<b>Direction of Rotation</b>		3-100	Same as Input		
<b>Degree of Protection</b>			IP65		
<b>Maximum Weight</b>	kg (lbs)	3 to 10	1.0 (2.2)	3.0 (6.6)	7.0 (15.4)
		15 to 100	2.0 (4.4)	5.0 (11.0)	10.0 (22.0)

1) At nominal speed  $N_{nom r}$ .

2) See gearhead selection program.

3) Maximum of 1000 stops.

4) For intermittent operation.

5) Max Radial Load applied to the center of the shaft at 100 rpm.

6) Max Axial Load at 100 rpm.

7) For combine Radial and Axial load consult Factory or use our software on the company website.

8) Measured at 2% of rated torque.

9) Measure at 1m.





## PX Gen II Output Shaft Load Rating

### PX60 / PX23

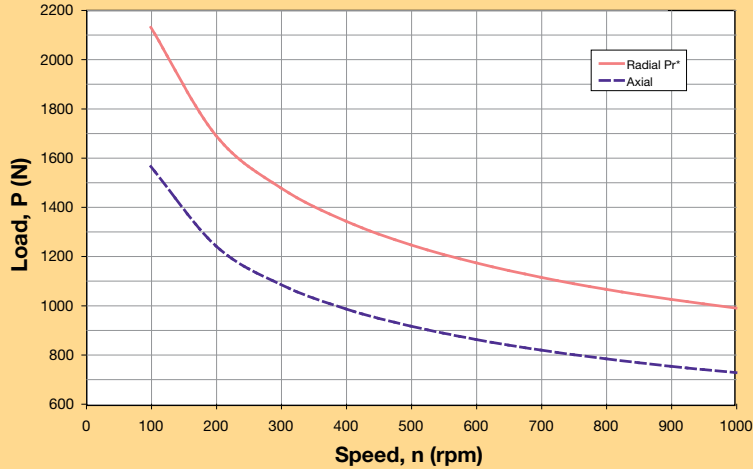

Formulas to calculate radial load ( $Pr_x$ ) at any distance "X" from the gearhead mounting surface:

$$Pr_x = Pr * 78 \text{ mm} / (63 + X)$$

$$Pr_x = Pr * 3.07 \text{ in} / (2.48 \text{ in} + X)$$

### PX90 / PX34

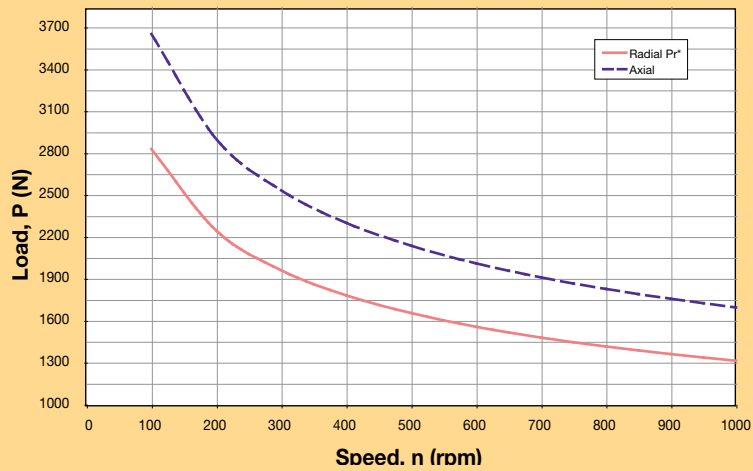

$$Pr_x = Pr * 95 \text{ mm} / (73 + X)$$

$$Pr_x = Pr * 3.74 \text{ in} / (2.87 \text{ in} + X)$$

### PX115 / PX42

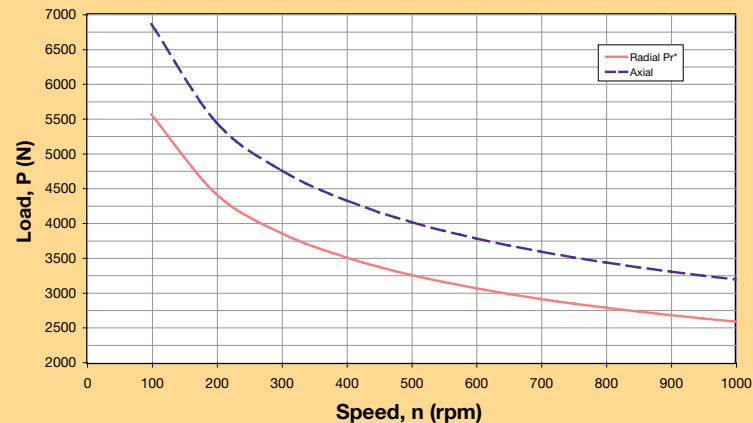

$$Pr_x = Pr * 115 \text{ mm} / (73 + X)$$

$$Pr_x = Pr * 4.53 \text{ in} / (3.43 \text{ in} + X)$$

\* Radial load applied to center of the shaft.

PX Series Gen II Dimensions

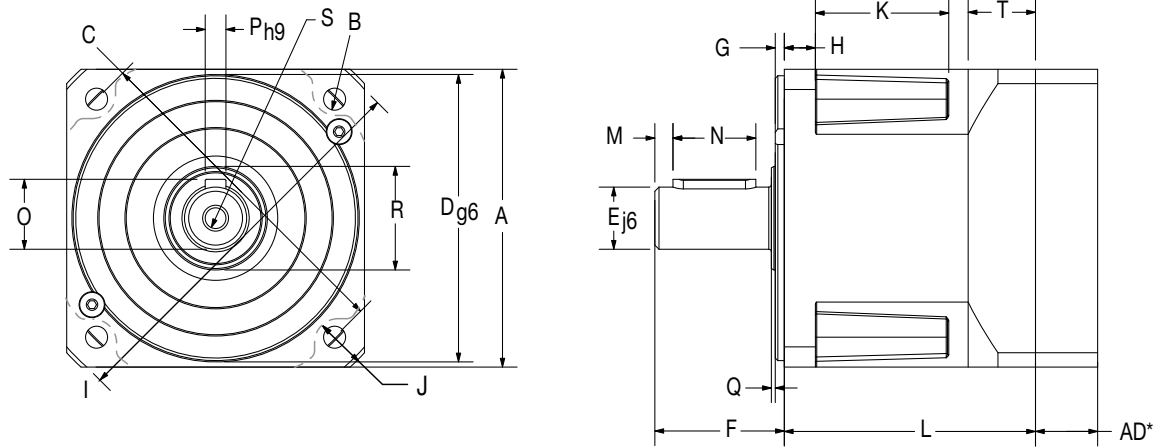

Metric Frame Sizes

Frame Size	A		B		C		D		E		F		G		H		I		J		K	
	Square Flange	Bolt Hole	Bolt Circle	Pilot Diameter	Output Shaft Diameter	Output Shaft Length	Pilot Thickness	Flange Thickness	Housing Diameter	Housing Recess	Recess Length											
	(mm) (in)	(mm) (in)	(mm) (in)	(mm) (in)	(mm) (in)	(mm) (in)	(mm) (in)	(mm) (in)	(mm) (in)	(mm) (in)	(mm) (in)	(mm) (in)	(mm) (in)	(mm) (in)	(mm) (in)	(mm) (in)	(mm) (in)	(mm) (in)	(mm) (in)	(mm) (in)	(mm) (in)	
PX60	62 2.441	5.5 0.217	70 2.756	50 1.969	16 0.630	25 0.984	2.5 0.098	8 0.315	82 3.228	5 0.197	24 0.945											
PX90	90 3.543	6.5 0.256	100 3.937	80 3.150	20 0.787	40 1.575	3 0.118	10 0.394	116 4.567	6.5 0.256	33 1.299											
PX115	115 4.528	8.5 0.335	130 5.118	110 4.331	24 0.945	50 1.969	3.5 0.138	14 0.551	152 5.984	7.5 0.295	42 1.654											

Frame Size	L1		L2		M		N		O		P		Q		R		S		T	
	Length Single Stage	Length Double Stage	Distance from Shaft End	Keyway Length	Key Height	Keyway Width	Shoulder Height	Shoulder Diameter	Tap & Depth (end of shaft)	Rear Housing Thickness										
	(mm) (in)	(mm) (in)	(mm) (in)	(mm) (in)	(mm) (in)	(mm) (in)	(mm) (in)	(mm) (in)	(mm) (in)	(mm) (in)	(mm) (in)	(mm) (in)	(mm) (in)	(mm) (in)	(mm) (in)	(mm) (in)	(mm) (in)	(mm) (in)	(mm) (in)	(mm) (in)
PX60	70.3 2.768	105.3 4.146	3 0.118	16 0.630	18 0.709	5 0.197	1 0.039	22 0.866	M5x8	20.3 0.799										
PX90	80 3.150	123.5 4.862	5 0.197	28 1.102	22.5 0.886	6 0.236	1 0.039	35 1.378	M8x16	20 0.787										
PX115	97 3.819	150.2 5.913	7 0.276	32 1.260	27 1.063	8 0.315	1.5 0.059	50 1.969	M8x16	26 1.024										

NEMA Frame Sizes

Frame Size	B		C		D		E		F		N		O		P	
	Bolt Hole	Bolt Circle	Pilot Diameter	Output Shaft Diameter	Output Shaft Length	Keyway Length	Keyway Depth	Keyway Width								
	(in) (mm)	(in) (mm)	(in) (mm)	(in) (mm)	(in) (mm)	(in) (mm)	(in) (mm)	(in) (mm)	(in) (mm)	(in) (mm)	(in) (mm)	(in) (mm)	(in) (mm)	(in) (mm)	(in) (mm)	
PX23	0.2 4.953	2.633 66.675	1.5 38.100	0.38 9.525	1 25.400	— —	— —	— —								
PX34	0.22 5.512	3.88 98.425	2.88 73.025	0.5 12.700	1.25 31.750	1.06 27.000	0.07 1.829	0.13 3.251								
PX42	0.28 7.137	4.95 125.730	2.19 55.550	0.63 15.875	1.5 38.100	1.14 29.007	0.09 2.388	0.19 4.775								

PX23 has a flat on output shaft, not a keyway

NOTE: NEMA Sizes have 20% lower torque/stiffness ratings due to smaller output shaft diameter.



## Universal Mounting Kits

Adapter Length "AD" Dimension

Frame Size	Motor Shaft Length		Gearhead Adapter Length	
	mm	(in)	mm	(in)
60	16 thru 35	(0.630 thru 1.378)	16.5	(0.65)
	35.1 thru 41	(1.382 thru 1.614)	22.5	(0.886)
90	20 thru 40	(0.787 thru 1.575)	20	(0.787)
	40.1 thru 48	(1.579 thru 1.890)	28.5	(1.122)
115	22 thru 50	(0.866 thru 1.969)	24	(0.945)
	50.1 thru 61	(1.972 thru 2.402)	35	(1.378)

## PX Series Gen II Inertia

All moment of inertia values are as reflected at the input of the gearhead

Ratio	Units*	PX60 / PX23	PX90 / PX34	PX115 / PX42
3	kg cm <sup>2</sup>	0.2500	0.9700	3.4000
	in lb sec <sup>2</sup>	0.000221	0.000858	0.003009
4	kg cm <sup>2</sup>	0.1700	0.6700	2.2000
	in lb sec <sup>2</sup>	0.000150	0.000593	0.001947
5	kg cm <sup>2</sup>	0.1500	0.5100	1.7000
	in lb sec <sup>2</sup>	0.000133	0.000451	0.001505
7	kg cm <sup>2</sup>	0.1400	0.4100	1.3000
	in lb sec <sup>2</sup>	0.000124	0.000363	0.001151
10	kg cm <sup>2</sup>	0.1400	0.3700	1.1000
	in lb sec <sup>2</sup>	0.000124	0.000327	0.000974
15	kg cm <sup>2</sup>	0.1500	0.5200	0.1700
	in lb sec <sup>2</sup>	0.150000	0.000460	0.000150
20	kg cm <sup>2</sup>	0.1500	0.5100	1.7000
	in lb sec <sup>2</sup>	0.000133	0.000451	0.001505
25	kg cm <sup>2</sup>	0.1500	0.5100	1.7000
	in lb sec <sup>2</sup>	0.000133	0.000451	0.001505
30, 40, 50, 70, 100	kg cm <sup>2</sup>	0.1300	0.3700	1.1000
	in lb sec <sup>2</sup>	0.000115	0.000327	0.000974

\* Note: 1 kg cm<sup>2</sup> = 0.000885 in lb sec<sup>2</sup>

RS Gen II Performance Specifications

Parameter	Units	Ratio	RS60 Gen II		RS90 Gen II		RS115 Gen II	
<b>Nominal Output Torque</b> <sup>1)</sup> $T_{nom r}$	Nm (inlbs)	5	13	(115)	55	(487)	85	(752)
		10	24	(212)	80	(708)	160	(1,415)
		15,20,25,50	35	(310)	88	(779)	220	(1,947)
		30,40,100	30	(266)	86	(752)	195	(1,726)
<b>Maximum Acceleration Output Torque</b> <sup>2)</sup> $T_{acc r}$	Nm (inlbs)	5	19	(168)	83	(743)	127	(1,124)
		10	36	(320)	120	(743)	240	(2,124)
		15,20,25,50	45	(400)	123	(867)	255	(2,257)
		30,40,100	37	(327)	112	(797)	240	(2,124)
<b>Emergency Stop Output Torque</b> <sup>3)</sup> $T_{em r}$	Nm (inlbs)	5	40	(355)	150	(1,327)	270	(2,390)
		10	72	(637)	240	(2,125)	480	(4,248)
		15,20,25,50	80	(708)	250	(2,213)	510	(4,514)
		30,40,100	60	(531)	200	(1,770)	430	(3,806)
<b>Nominal Input Speed</b> $N_{nom r}$	RPM	5,10	3200		2800		2400	
		15,20,25,30, 40	3700		3300		2900	
		50,100	4200		3800		3400	
<b>Maximum Input Speed</b> $N_{max r}$ <sup>4)</sup>	RPM	5-100	6000		5300		4500	
<b>Maximum Radial Load</b> $Pr_{max}$ <sup>5,7)</sup>	N (lbs)		1650	(370)	4800	(1,080)	7500	(1,685)
<b>Maximum Axial Load</b> $Pa_{max}$ <sup>6)</sup>	N (lbs)		2100	(475)	3600	(810)	6800	(1,530)
<b>Service Life</b>	h		20,000					
<b>Standard Backlash</b> <sup>8)</sup>	arc min	5 to 10	<14		<12		<12	
		15 to 100	<12		<10		<10	
<b>Low Backlash</b> <sup>8)</sup>	arc min	5 to 10	<10		<8		<8	
		15 to 100	<8		<6		<6	
<b>Efficiency at Nominal Torque</b>	%	5 to 10	94		94		94	
<b>Noise Level at 3000 RPM</b> <sup>9)</sup>	db	5-100	<65		<68		<68	
<b>Torsional Stiffness</b>	Nm/arcmin (inlb/arcmin)	5-100	2.5	(22)	10	(90)	22	(195)
<b>Maximum Allowable Case Temperature</b>	° C	5-100	-20 to 90					
<b>Lubrication</b>		5-100	Per Maintenance Schedule					
<b>Mounting Position</b>		5-100	Any					
<b>Degree of Protection</b>			IP65					
<b>Maximum Weight</b>	kg (lbs)	5 to 10	2.0	(4.4)	6.0	(13.2)	11.0	(24.2)

1) At nominal speed  $N_{nom r}$ .  
 2) See gearhead selection program.  
 3) Maximum of 1000 stops.  
 4) For intermittent operation.  
 5) Max Radial Load applied to the center of the shaft at 100 rpm.  
 6) Max Axial Load at 100 rpm.  
 7) For combine Radial and Axial load consult Factory or use our software on the company website.  
 8) Measured at 2% of rated torque.  
 9) Measure at 1m.



## RS Gen II Output Shaft Load Rating

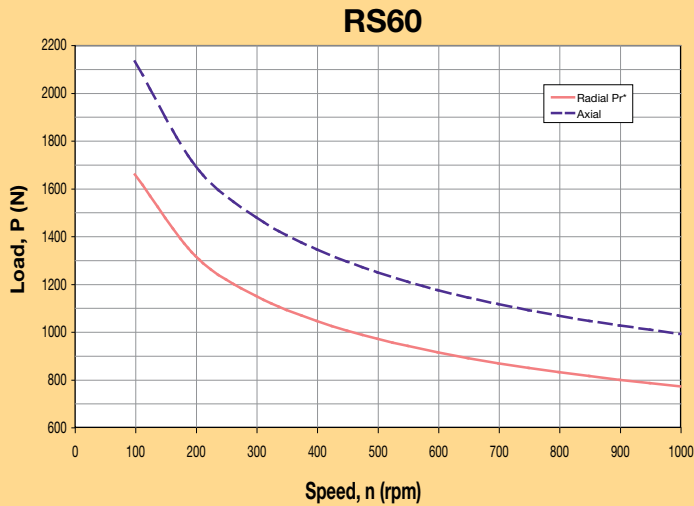

Formulas to calculate radial load ( $P_{rx}$ ) at any distance "X" from the gearhead mounting surface:

$$P_{rx} = P_r * 75 \text{ mm} / (49 + X)$$

$$P_{rx} = P_r * 2.95 \text{ in} / (1.93 \text{ in} + X)$$

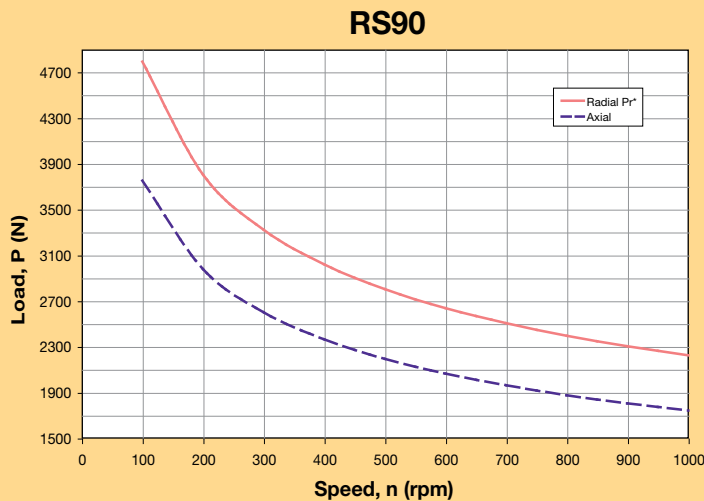

$$P_{rx} = P_r * 96 \text{ mm} / (62 + X)$$

$$P_{rx} = P_r * 3.78 \text{ in} / (2.44 \text{ in} + X)$$

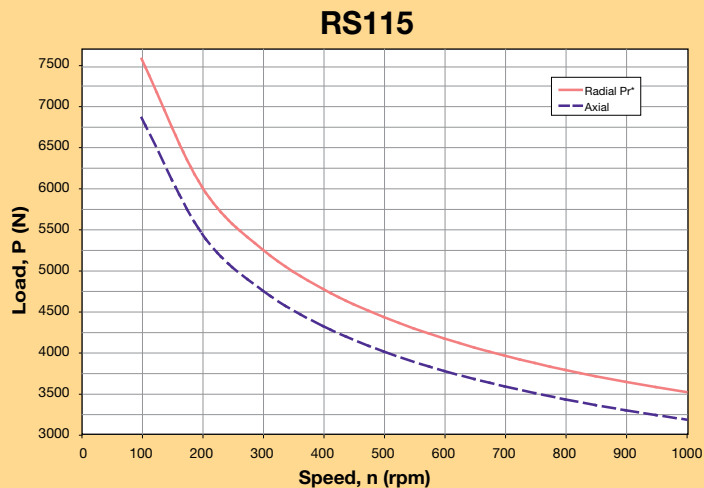

$$P_{rx} = P_r * 124 \text{ mm} / (81 + X)$$

$$P_{rx} = P_r * 4.88 \text{ in} / (3.19 \text{ in} + X)$$

\* Radial load applied to center of the shaft.

## RS Series Gen II Dimensions

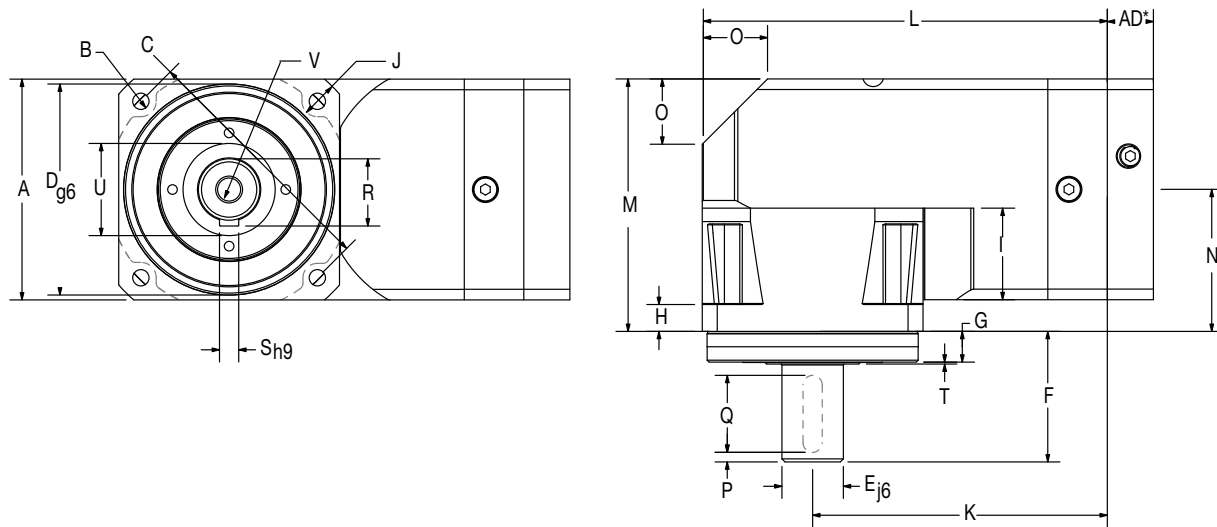

### Metric Frame Sizes

Frame Size	A Square Flange		B Bolt Hole		C Bolt Circle		D Pilot Diameter		E Output Shaft Diameter		F Output Shaft Length		G Pilot Thickness		H Flange Thickness		I Recess Length		J Housing Recess	
	(mm)	(in)	(mm)	(in)	(mm)	(in)	(mm)	(in)	(mm)	(in)	(mm)	(in)	(mm)	(in)	(mm)	(in)	(mm)	(in)	(mm)	(in)
<b>RS60</b>	62	2.441	5.5	0.217	70	2.756	50	1.969	16	0.630	40	1.575	11	0.433	8	0.315	23.5	0.925	5	0.197
<b>RS90</b>	90	3.543	6.5	0.256	100	3.937	80	3.150	22	0.866	52	2.047	15	0.591	10	0.394	40.5	1.594	6.5	0.256
<b>RS115</b>	115	4.528	8.5	0.335	130	5.118	110	4.331	32	1.260	68	2.677	16	0.630	14	0.551	47.5	1.870	7.5	0.295

Frame Size	K Distance to Output Centerline		L Housing Length		M Housing Width		N Distance to Input Centerline		O Taper Distance		P Distance from Shaft End		Q Keyway Length		R Key Height		S Keyway Width		T Shoulder Height	
	(mm)	(in)	(mm)	(in)	(mm)	(in)	(mm)	(in)	(mm)	(in)	(mm)	(in)	(mm)	(in)	(mm)	(in)	(mm)	(in)	(mm)	(in)
<b>RS60</b>	93.7	3.689	124.7	4.909	76.8	3.024	47	1.850	14	0.551	2	0.079	25	0.984	18	0.709	5	0.197	0.5	0.020
<b>RS90</b>	132	5.197	177	6.969	103	4.055	58	2.283	25	0.984	3	0.118	32	1.260	24.5	0.965	6	0.236	0.5	0.020
<b>RS115</b>	153.5	6.043	211	8.307	132	5.177	74	2.913	32	1.260	5	0.197	40	1.575	35	1.378	10	0.394	1	0.039

Frame Size	U Shoulder Diameter		V Tap & Depth (end of shaft)
	(mm)	(in)	
<b>RS60</b>	22	0.866	M5x8
<b>RS90</b>	35	1.378	M8x16
<b>RS115</b>	45	1.772	M12x25



## Universal Mounting Kits

Adapter Length "AD" Dimension

Frame Size	Motor Shaft Length		Gearhead Adapter Length	
	mm	(in)	mm	(in)
60	16 thru 35	(0.630 thru 1.378)	16.5	(0.65)
	35.1 thru 41	(1.382 thru 1.614)	22.5	(0.886)
90	20 thru 40	(0.787 thru 1.575)	20	(0.787)
	40.1 thru 48	(1.579 thru 1.890)	28.5	(1.122)
115	22 thru 50	(0.866 thru 1.969)	24	(0.945)
	50.1 thru 61	(1.972 thru 2.402)	35	(1.378)

## RS Series Gen II Inertia

All moment of inertia values are as reflected at the input of the gearhead

Ratio	Units*	RS60	RS90	RS115
5	kg cm <sup>2</sup>	0.2200	0.8100	2.5000
	in lb sec <sup>2</sup>	0.000195	0.000717	0.002213
10	kg cm <sup>2</sup>	0.1900	0.6100	1.9000
	in lb sec <sup>2</sup>	0.000168	0.000540	0.001682
15	kg cm <sup>2</sup>	0.1800	0.6000	1.7000
	in lb sec <sup>2</sup>	0.150000	0.000531	0.001505
20	kg cm <sup>2</sup>	0.1700	0.5100	1.4000
	in lb sec <sup>2</sup>	0.000150	0.000451	0.001239
25	kg cm <sup>2</sup>	0.1600	0.4200	1.3000
	in lb sec <sup>2</sup>	0.000142	0.000372	0.001151
30	kg cm <sup>2</sup>	0.1800	0.6000	1.7000
	in lb sec <sup>2</sup>	0.000159	0.000531	0.001505
40	kg cm <sup>2</sup>	0.1700	0.5100	1.4000
	in lb sec <sup>2</sup>	0.000150	0.000451	0.001239
50	kg cm <sup>2</sup>	0.1500	0.4000	1.1000
	in lb sec <sup>2</sup>	0.000133	0.000354	0.000974
100	kg cm <sup>2</sup>	0.1500	0.4000	1.1000
	in lb sec <sup>2</sup>	0.000133	0.000354	0.000974

\* Note: 1 kg cm<sup>2</sup> = 0.000885 in lb sec<sup>2</sup>

RX Gen II Performance Specifications

Parameter	Units	Ratio	RX60 Gen II		RX90 Gen II		RX115 Gen II	
<b>Nominal Output Torque <sup>1)</sup></b> <b>T<sub>nom r</sub></b>	Nm (inlbs)	5	10	(89)	44	(390)	68	(602)
		10	19	(168)	64	(566)	128	(566)
		15,20,25,50	24	(212)	66	(585)	136	(584)
		30,40,100	20	(177)	60	(530)	128	(531)
<b>Maximum Acceleration Output Torque <sup>2)</sup></b> <b>T<sub>acc r</sub></b>	Nm (inlbs)	5	15	(133)	66	(584)	102	(903)
		10	28	(248)	96	(850)	192	(1,700)
		15,20,25,50	36	(319)	100	(885)	204	(1,805)
		30,40,100	30	(266)	90	(797)	192	(1,700)
<b>Emergency Stop Output Torque <sup>3)</sup></b> <b>T<sub>em r</sub></b>	Nm (inlbs)	5	32	(283)	120	(1,062)	216	(1,912)
		10	58	(513)	192	(1,700)	384	(3,398)
		15,20,25,50	64	(566)	200	(1,770)	408	(3,611)
		30,40,100	48	(425)	160	(1,416)	345	(3,053)
<b>Nominal Input Speed N<sub>nom r</sub></b>	RPM	5,10	3200		2800		2400	
		15,20,25,30, 40	3700		3300		2900	
		50,100	4200		3800		3400	
<b>Maximum Input Speed N<sub>max r</sub> <sup>4)</sup></b>	RPM	5-100	6000		5300		4500	
<b>Maximum Radial Load Pr<sub>max</sub> <sup>5,7)</sup></b>	N (lbs)		1550	(348)	2800	(1,079)	5500	(1,236)
<b>Maximum Axial Load Pa<sub>max</sub> <sup>6)</sup></b>	N (lbs)		2100	(475)	3600	(810)	6800	(1,530)
<b>Service Life</b>	h		20,000					
<b>Standard Backlash <sup>8)</sup></b>	arc min	5 to 10	<20		<18		<16	
		15 to 100	<20		<18		<16	
<b>Low Backlash <sup>8)</sup></b>	arc min	5 to 10	<18		<16		<14	
		15 to 100	<16		<14		<12	
<b>Efficiency at Nominal Torque</b>	%	5 to 10	94		94		94	
<b>Noise Level at 3000 RPM <sup>9)</sup></b>	db	5-100	<65		<68		<68	
<b>Torsional Stiffness</b>	Nm/arcmin (inlb/arcmin)	5-100	2.5	(22)	10	(90)	22	(195)
<b>Maximum Allowable Case Temperature</b>	° C	5-100	-20 to 90					
<b>Lubrication</b>		5-100	Per Maintenance Schedule					
<b>Mounting Position</b>		5-100	Any					
<b>Degree of Protection</b>			IP65					
<b>Maximum Weight</b>	kg (lbs)	5 to 10	2.0	(4.4)	6.0	(13.2)	11.0	(24.2)

1) At nominal speed N<sub>nom r</sub>.  
2) See gearhead selection program.  
3) Maximum of 1000 stops.  
4) For intermittent operation.  
5) Max Radial Load applied to the center of the shaft at 100 rpm.  
6) Max Axial Load at 100 rpm.  
7) For combine Radial and Axial load consult Factory or use our software on the company website.  
8) Measured at 2% of rated torque.  
9) Measure at 1m.





## RX Gen II Output Shaft Load Rating

### RX60 / RX23

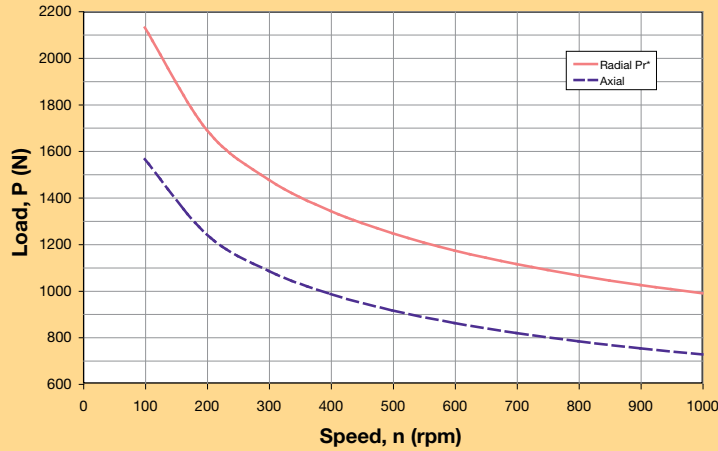

Formulas to calculate radial load ( $Pr_x$ ) at any distance "X" from the gearhead mounting surface:

$$Pr_x = Pr * 78 \text{ mm} / (63 + X)$$

$$Pr_x = Pr * 3.07 \text{ in} / (2.48 \text{ in} + X)$$

### RX90 / RX34

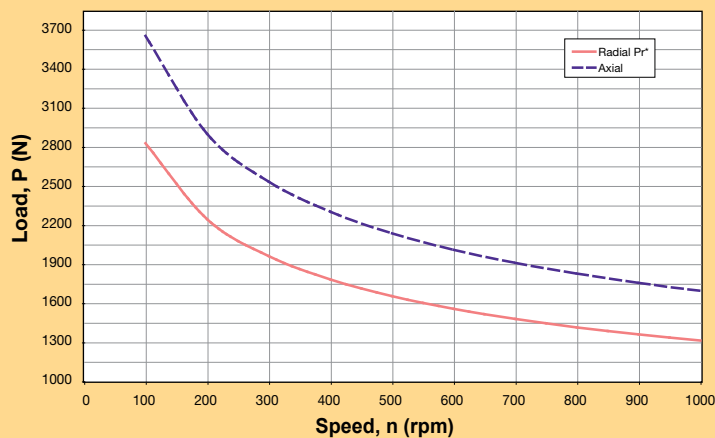

$$Pr_x = Pr * 95 \text{ mm} / (73 + X)$$

$$Pr_x = Pr * 3.74 \text{ in} / (2.87 \text{ in} + X)$$

### RX115 / RX42

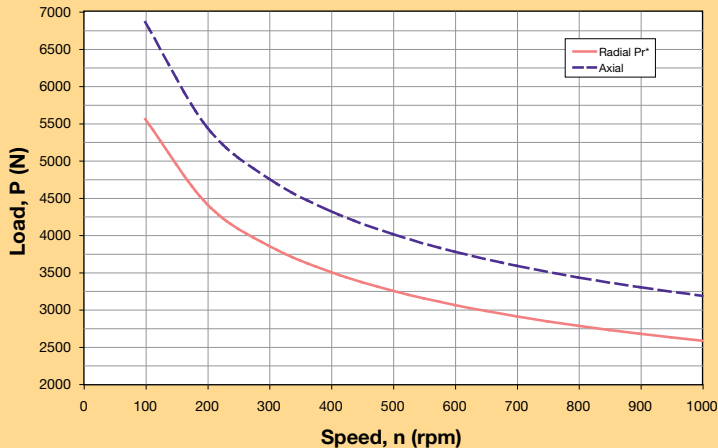

$$Pr_x = Pr * 115 \text{ mm} / (73 + X)$$

$$Pr_x = Pr * 4.53 \text{ in} / (3.43 \text{ in} + X)$$

\* Radial load applied to center of the shaft.

## RX Series Gen II Dimensions

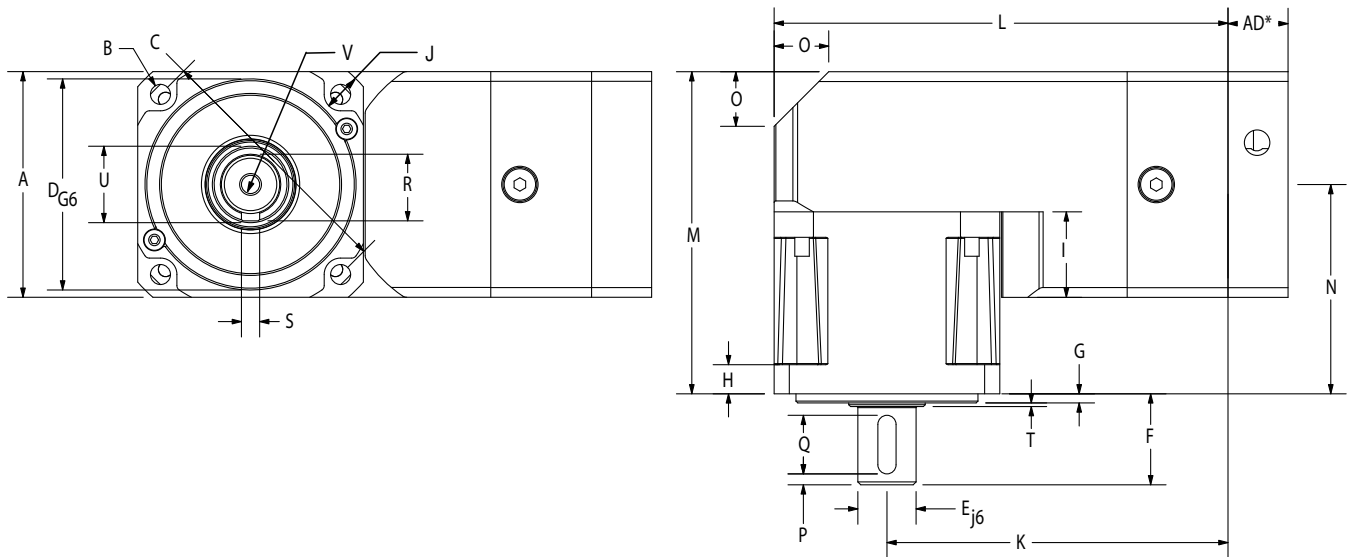

### Metric Frame Sizes

Frame Size	A		B		C		D		E		F		G		H		I		J		K	
	Square Flange		Bolt Hole		Bolt Circle		Pilot Diameter		Output Shaft Diameter		Output Shaft Length		Pilot Thickness		Flange Thickness		Recess Length		Housing Recess		Distance to Output Centerline	
	(mm)	(in)	(mm)	(in)	(mm)	(in)	(mm)	(in)	(mm)	(in)	(mm)	(in)	(mm)	(in)	(mm)	(in)	(mm)	(in)	(mm)	(in)	(mm)	(in)
<b>RX60</b>	62	2.441	5.5	0.217	70	2.756	50	1.969	16	0.630	25	0.984	2.5	0.098	13	0.512	23.5	0.925	5	0.197	93.7	3.689
<b>RX90</b>	90	3.543	6.5	0.256	100	3.937	80	3.150	20	0.787	40	1.575	3	0.118	17	0.669	36.5	1.437	6.5	0.256	132	5.197
<b>RX115</b>	115	4.528	8.5	0.335	130	5.118	110	4.331	24	0.945	50	1.969	3.5	0.138	20	0.787	47.5	1.870	7.5	0.295	153.5	6.043

Frame Size	L		M		N		O		P		Q		R		S		T		U		V Tap & Depth (end of shaft)
	Housing Length		Housing Width		Distance to Input Centerline		Taper Distance		Distance from Shaft End		Keyway Length		Key Height		Keyway Width		Shoulder Height		Shoulder Diameter		
	(mm)	(in)	(mm)	(in)	(mm)	(in)	(mm)	(in)	(mm)	(in)	(mm)	(in)	(mm)	(in)	(mm)	(in)	(mm)	(in)	(mm)	(in)	
<b>RX60</b>	124.5	4.902	88.5	3.484	57.5	2.264	14	0.551	3	0.118	16	0.630	18	0.709	5	0.197	0.5	0.020	22	0.866	M5x8
<b>RX90</b>	177	6.969	114	4.469	68.5	2.697	25	0.984	5	0.197	28	1.102	24.5	0.965	6	0.236	0.5	0.020	35	1.378	M8x16
<b>RX115</b>	211	8.307	138	5.445	81	3.189	32	1.260	7	0.276	32	1.260	27	1.063	8	0.315	1	0.039	45	1.772	M8x16

### NEMA Frame Sizes

Frame Size	B		C		D		E		F		Q		R		S	
	Bolt Hole		Bolt Circle		Pilot Diameter		Output Shaft Diameter		Output Shaft Length		Keyway Length		Keyway Depth		Keyway Width	
	(in)	(mm)	(in)	(mm)	(in)	(mm)	(in)	(mm)	(in)	(mm)	(in)	(mm)	(in)	(mm)	(in)	(mm)
<b>RX23</b>	0.2	4.953	2.633	66.675	1.5	38.100	0.38	9.525	1	25.400	—	—	—	—	—	—
<b>RX34</b>	0.22	5.512	3.88	98.425	2.88	73.025	0.5	12.700	1.25	31.750	1.06	27.000	0.07	1.829	0.13	3.251
<b>RX42</b>	0.28	7.137	4.95	125.730	2.19	55.550	0.63	15.875	1.5	38.100	1.14	29.007	0.09	2.388	0.19	4.775

RX23 has a flat on output shaft, not a keyway

NOTE: NEMA Sizes have 20% lower torque/stiffness ratings due to smaller output shaft diameter.



## Universal Mounting Kits

Adapter Length "AD" Dimension

Frame Size	Motor Shaft Length		Gearhead Adapter Length	
	mm	(in)	mm	(in)
60	16 thru 35	(0.630 thru 1.378)	16.5	(0.65)
	35.1 thru 41	(1.382 thru 1.614)	22.5	(0.886)
90	20 thru 40	(0.787 thru 1.575)	20	(0.787)
	40.1 thru 48	(1.579 thru 1.890)	28.5	(1.122)
115	22 thru 50	(0.866 thru 1.969)	24	(0.945)
	50.1 thru 61	(1.972 thru 2.402)	35	(1.378)

## RX Series Gen II Inertia

All moment of inertia values are as reflected at the input of the gearhead

Ratio	Units*	RX60 / RX23	RS90 / RX34	RS115 / RX42
5	kg cm <sup>2</sup>	0.2200	0.8100	2.5000
	in lb sec <sup>2</sup>	0.000195	0.000717	0.002213
10	kg cm <sup>2</sup>	0.1900	0.6100	1.9000
	in lb sec <sup>2</sup>	0.000168	0.000540	0.001682
15	kg cm <sup>2</sup>	0.1800	0.6000	1.7000
	in lb sec <sup>2</sup>	0.150000	0.000531	0.001505
20	kg cm <sup>2</sup>	0.1700	0.5100	1.4000
	in lb sec <sup>2</sup>	0.000150	0.000451	0.001239
25	kg cm <sup>2</sup>	0.1600	0.4200	1.3000
	in lb sec <sup>2</sup>	0.000142	0.000372	0.001151
30	kg cm <sup>2</sup>	0.1800	0.6000	1.7000
	in lb sec <sup>2</sup>	0.000159	0.000531	0.001505
40	kg cm <sup>2</sup>	0.1700	0.5100	1.4000
	in lb sec <sup>2</sup>	0.000150	0.000451	0.001239
50	kg cm <sup>2</sup>	0.1500	0.4000	1.1000
	in lb sec <sup>2</sup>	0.000133	0.000354	0.000974
100	kg cm <sup>2</sup>	0.1500	0.4000	1.1000
	in lb sec <sup>2</sup>	0.000133	0.000354	0.000974

\* Note: 1 kg cm<sup>2</sup> = 0.000885 in lb sec<sup>2</sup>

## Gen II How to Order

Choose gearhead series, frame size, ratio, backlash and specify motor, make and model for mounting kit from the charts below.

### Gearhead Ordering Information

Order Example:		①	②	-	③	-	④	-	⑤	⑥
		PS	60	-	003	-	XXX	-	S	2
①	②	③		④			⑤	⑥		
Series	Frame Size	Ratio		Special	Backlash	GEN 2				
PS	60, 90, 115	003, 004, 005, 007, 010, 015, 020, 025, 030, 040, 050, 070, 100		Factory Assigned (Only if needed)	S = Standard L = Low					
PX	60, 90, 115, 23, 34, 42	003, 004, 005, 007, 010, 015, 020, 025, 030, 040, 050, 070, 100								
RS	60, 90, 115	005, 010, 015, 020, 025, 030, 040, 050, 100								
RX	60, 90, 115, 23, 34, 42	005, 010, 015, 020, 025, 030, 040, 050, 100								

### Universal Mounting Kit Ordering Information

Order Example:		⑦	-	⑧
		MU	60	XXX
⑦	⑧			
Universal Mounting*	Frame Size **	Mounting Kit Suffix Number		
MU	60, 90, 115	See Motor Mounting Selection Tool for Part Number or Consult Factory		

\* Common to PS, PX, RS, RX and PV Series Gearheads

\*\*PX/RX23 use MU60, PX/RX34 use MU90, PX/RX42 use MU115

Universal Mounting Kit Adapter Length "AD" Dimension

Frame Size	Motor Shaft Length		Gearhead Adapter Length	
	mm	(in)	mm	(in)
60	16 thru 35	(0.630 thru 1.378)	16.5	(0.65)
	35.1 thru 41	(1.382 thru 1.614)	22.5	(0.886)
90	20 thru 40	(0.787 thru 1.575)	20	(0.787)
	40.1 thru 48	(1.579 thru 1.890)	28.5	(1.122)
115	22 thru 50	(0.866 thru 1.969)	24	(0.945)
	50.1 thru 61	(1.972 thru 2.402)	35	(1.378)

## Gen II Gearhead Sizing

Parker Bayside has prepared the following procedure to provide a quick method for selecting a gearhead.

### 1) Load Parameters.

- Acceleration time ( $t_{acc}$ )
- Continuous run time ( $t_{cont}$ )
- Deceleration time ( $t_{dec}$ )
- Dwell time ( $t_{dwell}$ )
- Acceleration torque ( $T_{acc}$ )
- Continuous torque ( $T_{cont}$ )
- Deceleration torque ( $T_{dec}$ )
- Continuous speed ( $N_{cont}$ )

### 2) Duty Cycle.

$$\text{Duty cycle} = \frac{t_{acc} + t_{cont} + t_{dec}}{(t_{acc} + t_{cont} + t_{dec} + t_{dwell})} \times 100\%$$

If duty cycle is <60% and ( $t_{acc} + t_{cont} + t_{dec}$ ) is less than 20 minutes, the motion is considered to be intermittent.

If duty cycle is >60% or ( $t_{acc} + t_{cont} + t_{dec}$ ) is greater than 20 minutes, the motion is considered to be continuous.

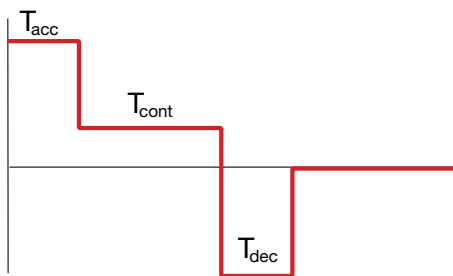
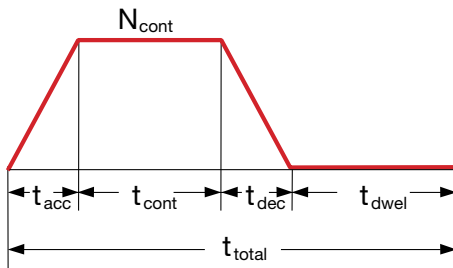

### 3) For Intermittent Duty Cycle:

Determine  $T_{acc}$  % of ( $T_{acc} + T_{cont} + T_{dec}$ ):

$$T_{acc} / (T_{acc} + T_{cont} + T_{dec}) \times 100\%$$

Define the ratio:  $T_{cont} / T_{acc}$

Use the table below to select the load factor K.

	Load Factor K							
$T_{acc}$ , %	10-15	15-20	20-25	25-30	30-35	35-40	40-45	45-50
$0 < T_{cont} / T_{acc} < 0.25$	1.0	1.0	0.94	0.88	0.81	0.76	0.71	0.66
$0.25 < T_{cont} / T_{acc} < 0.5$	1.0	0.95	0.89	0.84	0.79	0.75	0.70	0.66

Compare Accel/Decel torque to the rated accel torque  $T_{acc r}$ :

$$T_{acc} < T_{acc r} \times K, \text{ if not select another gearhead}$$

Compare Maximum speed to the Maximum rated speed:

$$N_{max} < N_{max r} / i \text{ i-gearhead ratio}$$

### 4) For Continuous Duty Cycle:

$$T_{nom} < T_{nom r}$$

$$N_{nom} < N_{nom r} / i$$

### 5) Check the Emergency Stop Torque Rating.

### 6) Verify Radial and Axial Shaft Load.

## Standard Options

### Gearheads Ready to Mount to Linear Actuators

Most belt driven linear slides need a gearhead to reduce inertia. Parker has pre-engineered in-line and right-angle gearheads to mount directly to most popular linear slides, eliminating the need for couplings or adapters.



### Mil-Spec Gearheads

Parker has extensive experience in military and aerospace applications. The Stealth Bomber, M1 Tank and the Space Shuttle all use Parker gearheads. Parker's quality system has been approved by NASA and the US Government to MIL-I-45208A.



### Input Shaft/Speed Reducer for Increased Design Flexibility

Parker gearheads are available with an input-shaft option. The input-shaft option allows more design flexibility, as options like brakes, encoders, or safety couplings can be used between the motor and the gearhead. Also, non-standard or oversized motors can be easily attached to the gearhead via an input shaft.



### Special Environments

Put a Parker gearhead anywhere! Parker can supply gearheads to operate in the harshest environments:

**Vacuum** - Available as a standard option to 10<sup>-7</sup> Torr vacuum ratings.

**Clean Room** - Special gearheads for Class 10,000 clean room applications.

**High Temperature** - Special lubricants and seals for temperatures up to 250° C.

**Radiation** - Gearheads customized to operate within radioactive environments.

**Food Grade** - Gearheads customized to operate within food-handling environments.



## PV Series Precision Gearheads



- **Higher radial load capacity:** Taper roller output bearings
- **Competitive Alternatives:** Five Drop-In Output Face Options
- **Universal mounting kits:** Quicker deliveries and easier mounting
- **Higher gear wear resistance:** Plasma Nitriding heat treating

The PV Series gearhead combines power and versatility in an economical package. It comes in a wide range of options including dimensional output face crossovers to the Parker Bayside PX, Alpha LP, Neugart PLE, Stober PE and Standard NEMA gearheads.

Product Series	Gear Geometry	Configuration	Frame Size (mm)	Continuous Torque (Nm)	Radial Load (N)	Backlash arc-min	IP Rating
PV40/17	Planetary	In-Line	40 (NEMA 17)	3.5 to 6.7	375 to 575	<15	IP64
PV60/23	Planetary	In-Line	60 (NEMA 23)	10.2 to 22.5	665 to 2535	<12	IP64
PV90/34	Planetary	In-Line	90 (NEMA 34)	33 to 71	1040 to 4270	<10	IP64

## MultiDrive RT, RD and RB Series Precision Gearheads



- **Space Saving: Compact, right-angle design saves space in many applications**
- **Smooth, Quiet Operation and Long Life: Hardened, precision spiral bevel gears ensure quiet operation**
- **Sealed Unit: Seals and o-rings provide IP65 protection to prevent leaks and to protect against harsh environments**

Stealth® MultiDrive (MD) offers three different output options for true flexibility. MultiDrive models include low-ratio, dual-shaft and hollow-shaft options in a compact, right angle package. With 5 frame sizes and multiple ratios to choose from, you are guaranteed to find a Stealth® MultiDrive to fit your servo motor application.

Product Series	Gear Geometry	Configuration	Frame Size (mm)	Continuous Torque (Nm)	Ratios	Backlash arc-min	IP Rating
RT	Spiral Bevel/ Helical	Right-Angle Thru Bore	90 to 220 (5 sizes)	34 to 565	3 to 30 (5 ratios)	<4	IP65
RD	Spiral Bevel/ Helical	Right-Angle Double Shaft	90 to 220 (5 sizes)	23 to 565	1 to 30 (7 ratios)	<4	IP65
RB	Spiral Bevel	Right-Angle	90 to 220 (5 sizes)	23 to 565	1 to 3 (3 ratios)	<4	IP65

## NE, NR Series Gearheads



- **Lightweight, aluminum housing and spur gearing**
- **Compact, short overall length and direct mounting to NEMA motors**
- **Low friction, low running torque, ideal for stepper motors**

Parker's NEMA gearheads feature a high-efficiency spur-gear design, in a light, compact package. Designed to mount directly to the face of NEMA face stepper and servo motors, NEMA gearheads are ideal for applications requiring low weight and low starting torque.

Product Series	Gear Geometry	Configuration	Frame Size	Continuous Torque (Nm)	Ratios	Backlash arc-min	IP Rating
NE	Spur	In-Line	NEMA 23 to 42 (3 sizes)	50 to 350	3 to 100 (9 ratios)	<10	IP54
NR	Bevel/Spur	Right-Angle	NEMA 23 to 42 (3 sizes)	50 to 350	1 to 100 (10 ratios)	<20	IP54

# EM Sales Offices

## Australia

**Parker Hannifin (Australia) Pty Limited**  
9 Carrington Road  
Castle Hill NSW 2154  
Australia  
Tel: +61 (0) 2 9842 5160  
Fax: +61 (0) 2 9634 3749

## Brazil

**Parker Hannifin Ind. Com Ltda.**  
Av. Lucas Nogueira Garcez 2181  
Esperança  
12325-900 Jacareí, SP  
Tel: 12 3954 5100  
Fax: 12 3954 5262  
Email: automation.brazil@parker.com

## China

**Parker Hannifin Motion & Control  
(Shanghai) Co., Ltd**  
280 Yuncqiao Rd, Jin Qiao Export  
Processing Zone  
Shanghai 201206, China  
Tel: (86-21) 50312525  
Fax: (86-21) 64459717

## France

**Parker SSD Parvex**  
8 avenue du Lac  
B.P. 249  
F-21007 Dijon Cedex  
Tel: +33 (0) 3 80 42 41 40  
Fax: +33 (0) 3 80 42 41 23

## Germany

**Electromechanical Europe  
Parker Hannifin GmbH & Co KG**  
Robert-Bosch-Strasse 22  
D-77656 Offenburg  
Germany  
Tel: +49 (0) 781 509 0  
Fax: +49 (0) 781 509 98176

## India

**Parker Hannifin (SSD Drives)**  
151 & 157 Developed Plots Estate  
Perungudi, Chennai 600 096  
Tel: 044-4391-0799  
Fax: 044-4391-0700

## Italy

**Parker Hannifin SpA  
(SSD Drives Division)**  
Via Gran Sasso, 7  
20030 Lentate sul Seveso -  
MI - Italy  
Tel: +39 0362 557308  
Fax: +39 0362 557312

## Korea

**Parker Hannifin Korea**  
6th Floor Daehwa Building  
169 Samsung-dong Kangnam-gu  
Seoul 135-882, South Korea  
Tel: +82 2 559 0400  
Fax: +82 2 556 8187

## Scotland and Northern Ireland

Unit 59  
Stirling Enterprise Park  
Player Road  
Stirling FK7 7RP  
Tel: +44 (0) 1786 471674  
Fax: +44 (0) 1786 451095

## Singapore

**Parker Hannifin Singapore Pte Ltd**  
11, Fourth ChinBee Road  
Singapore 619702  
Tel: (65) 6887 6300  
Fax: (65) 6265 5125/6261 4929

## Singapore Pte Ltd (Branch Office)

Lot 558A, Jalan Subang 3  
Off Persiaran Subang  
Sungai Penaga Industrial Park  
47610 Subang Jaya Malaysia  
Tel: (60) 03 5638 1476  
Fax: (60) 03 5638 1527

## Taiwan

**Parker Hannifin Taiwan Co., Ltd**  
No. 40, Wuchuan 3rd Road  
Wuku Industrial Park  
Taipei County, Taiwan 248  
ROC  
Tel: 886 2 2298 8987  
Fax: 886 2 2298 8982

## Thailand

**Parker Hannifin (Thailand) Co., Ltd.**  
1023, 3rd Floor, TPS Building,  
Pattanakarn Road,  
Suanluang, Bangkok 10250  
Thailand  
Tel: (66) 02717 8140  
Fax: (66) 02717 8148

## UK

**Parker Hannifin (Main Office)**  
New Courtwick Lane  
Littlehampton  
West Sussex BN17 7RZ  
United Kingdom  
Tel: +44 (0) 1903 737000  
Fax: +44 (0) 1903 737100

## USA

**Parker Hannifin Electromechanical  
Automation Division Main Office/  
Compumotor**  
5500 Business Park Drive  
Rohnert Park, CA 94928 USA  
Tel: 707-584-7558  
800-358-9070  
Fax: 707-584-8015  
Email: emn\_support@parker.com

**Parker Hannifin Electromechanical  
Automation Division/CTC**  
50 West TechneCenter Dr.  
Milford, OH 45150  
Tel: 513-831-2340  
800-233-3329  
Fax: 513-831-5042  
Email: emn\_moreinfo\_ctc@parker.com

**Parker Hannifin Electromechanical  
Automation Division/Bayside**  
27 Seaview Boulevard  
Port Washington, NY 11050  
Tel: 516-484-5353  
800-305-4555  
Fax: 516-629-8000  
Email: emn\_support\_bayside@parker.com

**Parker Hannifin Electromechanical  
Automation Division/Daedal**  
1140 Sandy Hill Road  
Irwin, PA 15642  
Tel: 724-861-8200  
800-245-6903  
Fax: 724-861-3330  
Email: ddlcat@parker.com

Catalog 8009  
7/08 Printed in U.S.A

## Parker Hannifin Corporation Electromechanical Automation Div.

Parker Bayside  
27 Seaview Boulevard  
Port Washington, NY 11050  
Phone: 800-305-4555  
Fax: 516-629-8000  
www.parkermotion.com

